

TM4[®] MOTIVE[™]

Integrated Motor / Inverter

Features

- Peak power: 150 kW
- Peak torque: 360 Nm
- Max operating speed: 11,000 RPM

Benefits

- Integrated motor and inverter system
- Compact solution: inverter 33% smaller than previous generation
- Designed according to ISO26262 ASIL-C principles
- Seamless integration into Dana's gearboxes and axles

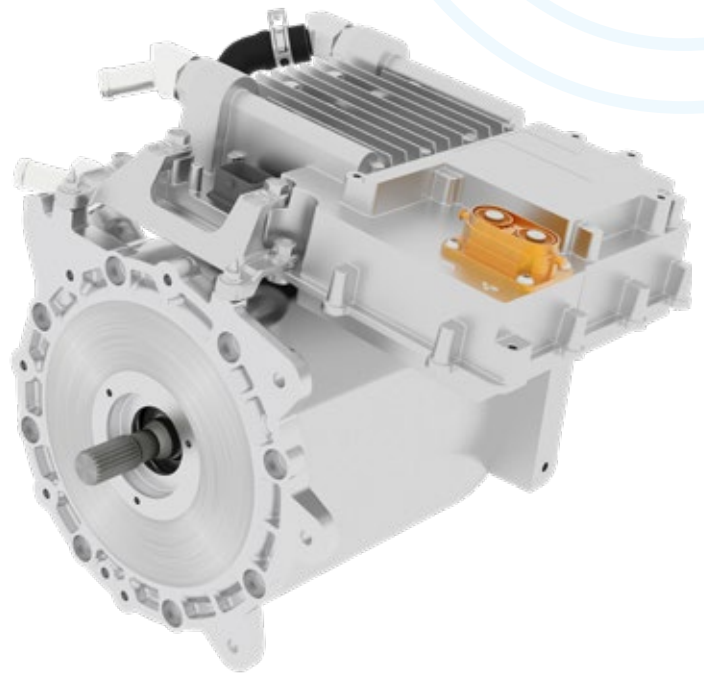

Optimized for passenger cars applications and up to class 2 commercial vehicles.



TM4[®] MOTIVE[™] Integrated Motor / Inverter

The TM4 MOTIVE series features integrated permanent magnet electric motors and power-dense electronic inverters. Designed according to ISO26262 standards, these systems are efficient turnkey solutions created expressly for light-duty electric vehicle and hybrid vehicle applications.

System Features

- 3-phase permanent magnet motor
- High specific torque/power system
- Low electro-magnetic audible noise
- Low-cogging and ripple torque for better NVH
- Thermal protection
- Variable switching frequency
- Medium voltage inverter (450 Vdc max)
- Reflex[™] gate driver technology for high power and current densities

Inverter Features

- System protection: IP 69K
- Max coolant inlet temperature: 65°C
- Coolant type: 40/60 water-glycol
- Toxic materials and flammability: ROHS, ELV, UL94-V0
- External corrosion resistance: Salt mist, chemical products

SYSTEM	Peak power	Continuous power	Peak torque	Continuous torque	Max operating speed
TM4 MOTIVE MV275	120 kW	70 kW	275 Nm	120 Nm	11,000 RPM
TM4 MOTIVE MV360	150 kW	90 kW	360 Nm	230 Nm	11,000 RPM

450 Vdc, 30 seconds, 45°C
Specifications are subject to change

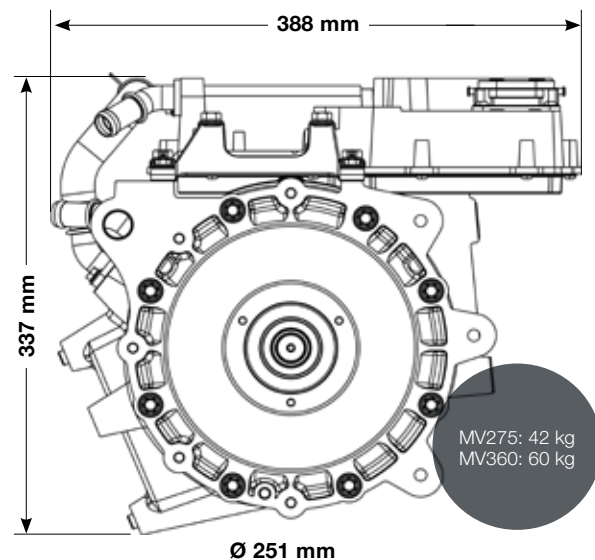
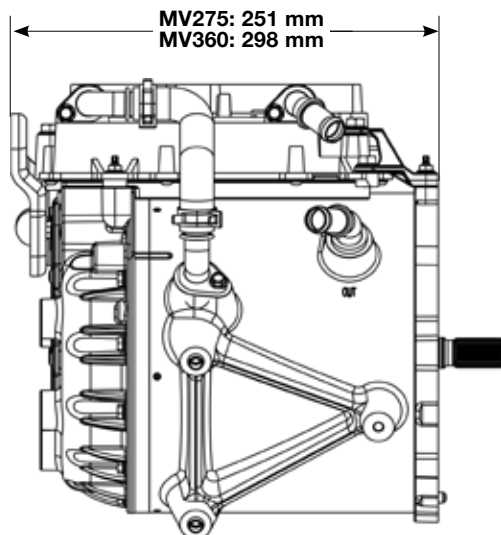

TM4.com

Application Policy

Capacity ratings, features, and specifications vary depending upon the model and type of service. Application approvals must be obtained from TM4; contact your representative for application approval. We reserve the right to change or modify our product specifications, configurations, or dimensions at any time without notice.

2019 TM4 Inc. All rights reserved.

