



TM4 SUMO™ LD Motor / Inverter System

Features

- Peak power: Up to 235 kW
- Peak torque: Up to 1200 Nm
- Max operating speed: 8600 RPM

Benefits

- High torque/low speed internal permanent magnet motor and inverter combinations
- Designed and validated as per axle mount requirements
- Seamless integration into Dana axles (example: eS9000r)

Standards

- System protection: IP67 / IP6K9K
- Shock and vibration standards: GMW3172 Sprung masses
- Max coolant inlet temperature: 65°C
- Coolant type: 40/60 water-glycol
- Toxic materials and flammability: ROHS, ELV, UL94-V0
- External corrosion resistance: Salt mist, chemical products

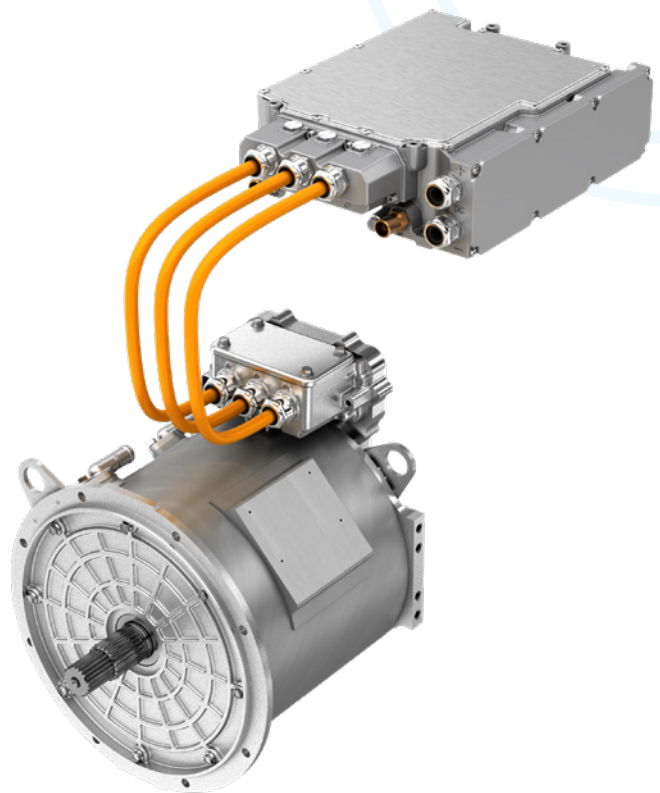

Ideal for Light Commercial Vehicles, Mini Buses, Medium-Duty Trucks, Medium Buses, and in e-Axles for Heavy-Duty Trucks.

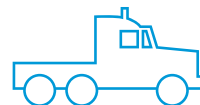
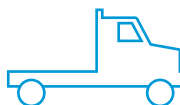
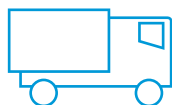

TM4 SUMO™ LD Motor / Inverter System

The TM4 SUMO LD systems are designed to interface directly with standard rear differentials and/or gearboxes and/or e-Axles. It makes this series perfect for light commercial vehicles and light bus platforms.

Motor Features

- 3-phase permanent magnet motor
- High torque and power density
- Low electro-magnetic audible noise
- Low-cogging and ripple torque
- Thermal protection
- Quick Connect option with HVIL for safe and easy installation or maintenance
- Range of male and female spline interfaces available

Inverter Features

- 3-phase high-voltage inverter
- Variable switching frequency
- Reflex™ gate driver technology for high power and current densities
- EMI Filter
- Best-in-class power density
- Quick Connect option with HVIL for safe and easy installation or maintenance

SYSTEM	INVERTER	PEAK POWER	CONTINUOUS POWER	PEAK TORQUE	CONTINUOUS TORQUE	MAX OPERATING SPEED	VOLTAGE RANGE
SUMO LD MV800-3P*	CO150	195 kW	115 kW	775 Nm	430 Nm	6500 RPM	130-450 Vdc
SUMO LD HV800-3P	CO150	235 kW	135 kW	950 Nm	420 Nm	8600 RPM	300-800 Vdc
SUMO LD HV1200-3P	CO150	175 kW	95 kW	1200 Nm	400 Nm	4500 RPM	300-800 Vdc

650 Vdc, 45°C / *350 Vdc, 45°C
Specifications are subject to change

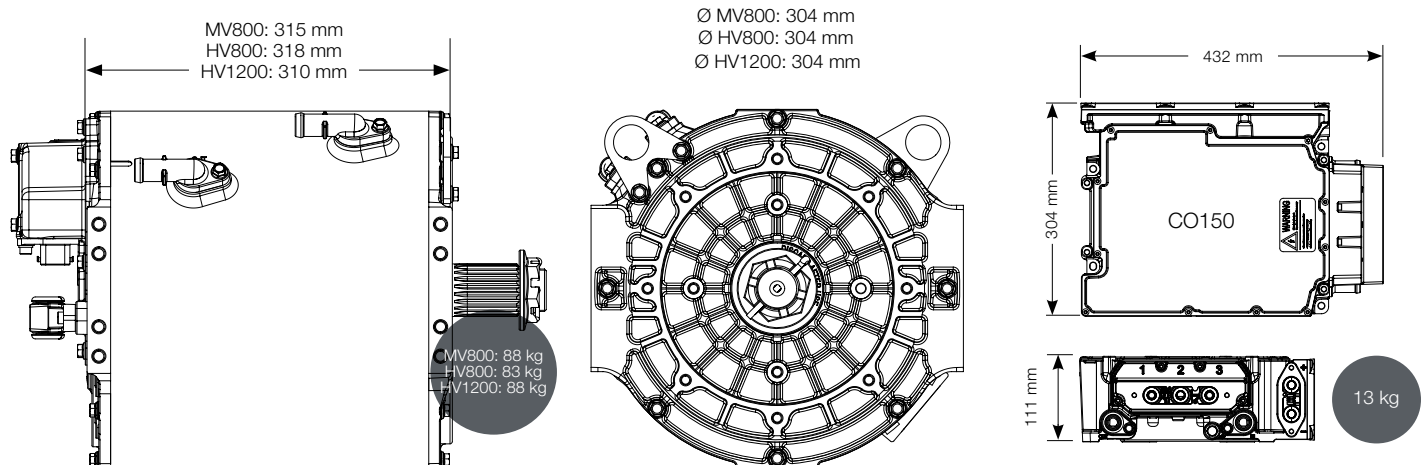

Dana.com/TM4

Application Policy

Capacity ratings, features, and specifications vary depending upon the model and type of service. Application approvals must be obtained from Dana TM4; contact your representative for application approval. We reserve the right to change or modify our product specifications, configurations, or dimensions at any time without notice.

