

Specifications

314

Dropbox



SPICER OFF-HIGHWAY PRODUCTS



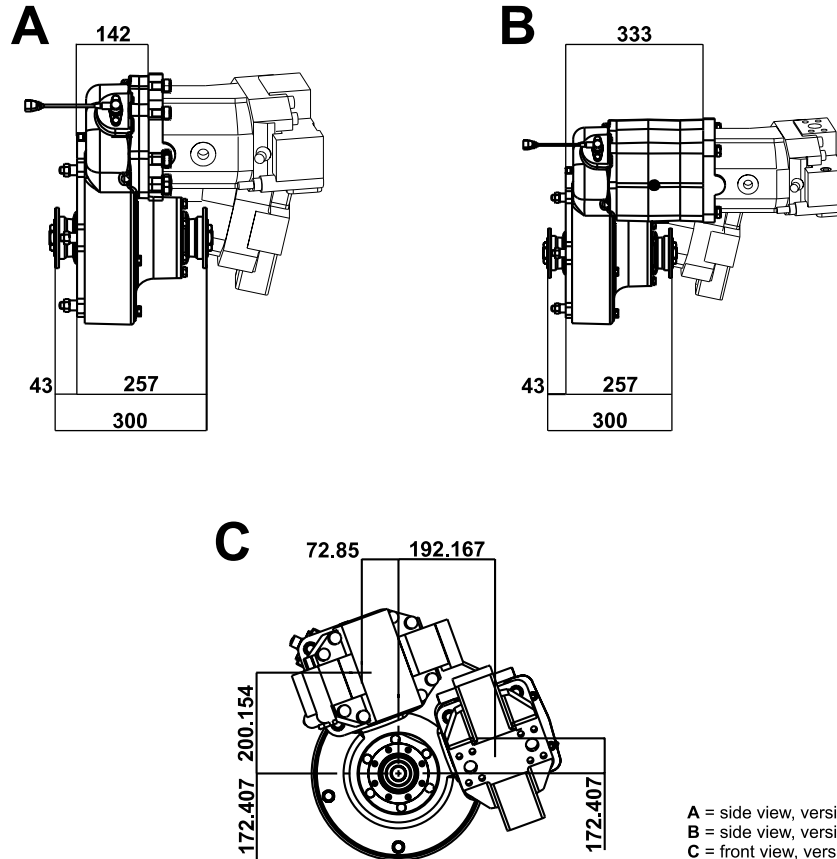

A = side view, version without clutch
 B = side view, version with clutch
 C = front view, version with two motors 160 cc

All dimensions are in mm

DESIGN FEATURES

The possibility to obtain 3 speed ranges without the need of gear changes is the main feature of this model 314. This dropbox is specially designed for industrial vehicles with an hydrostatic transmission where high speed vehicle range without shift problems is required and accommodates various combinations of hydraulic motors, from 80cc up to 160cc.

An input clutch allows disconnecting the second motor at high speed and re-engaging it when high torque is needed. The high efficiency of the system reduces the power loss and consequently the fuel consumption of the vehicle.

It can be supplied with these variations:

- Independently mounted or directly flanged to Spicer components
- Four wheel drive engagement
- Disconnectable PTO (Independently mounted only)
- With or without input clutch

TECHNICAL DATA

Input Torque continuous	2x960 Nm
Input power	75 kW
Speeds	1
Max. input speed	4000 RPM
OUTPUT FLANGE - YOKE OPTIONS - DIN - SAE - MECHANICS	
Ratios available	1:1.73 (for 80cc) 1:1.83 (for 107cc) 1:1.64 (for 140cc) 1:1.64 (for 160cc)



SPICER OFF-HIGHWAY AXLE DIVISION
 Zona Industriale - 38062 Arco (Trento), Italy
 Tel: +39 0464 580111 Fax: +39 0464 580444

APPLICATION POLICY
 Capability ratings, features and specifications vary depending upon the model type of service. Applications must be obtained from Spicer Off-Highway Axle Division. We reserve the right to change or modify our product specifications, configurations, or dimensions at any time without notice.