

# Spicer® Electrified™ e-Drive Axle

eS5700r

## Product Features

- Integrated motor and axle power system
- Intended GVW range: 4,535-6,349 kg
- Designed to be a “drop-in” to existing suspensions
- Adaptable axle tube configurations and braking systems
- Maximum power: 130 kW
- Nominal voltage: 380 VAC
- Water glycol-cooled motor and inverter
- Integrated electronically controlled park feature
- System weight with disc brakes: 305 kg

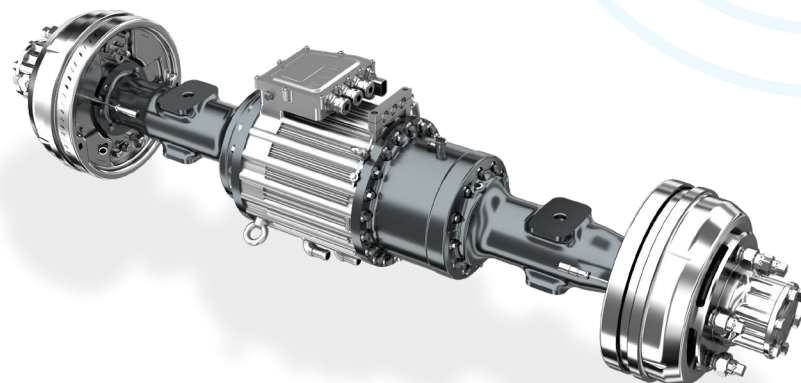

Ideal for Light Commercial Vehicles and Mini Buses



**SPICER**  
ELECTRIFIED

e-Drive Systems